

LINEAR 5 MK II 112 FA

THE ALL-PURPOSE WORKHORSE

Powerful full-range mid/high unit for setups with and without subwoofer

Part number: 1007961

The LINEAR 5 MK II 112 FA is a full-range mid/high unit with 12" woofer and a tweeter with 1.7" voice coil in a rotatable horn. The 60° x 40° dispersion pattern makes it easier to form speaker clusters.

In addition to crystal-clear, assertive sound with an energetic bass, the LINEAR 5 MK II 112 FA achieves even greater throw distances thanks to its longer horn. The remote-controllable high-performance DSP with integrated, directly selectable presets offers a DSP Out that can route the processed signal from the mid/high unit to a non-networked speaker.

The sturdy birch multiplex hybrid enclosure makes the LINEAR 5 MK II 112 FA a reliable partner for bands, DJs and sound technicians. Together with the LINEAR 5 MK II subwoofers, it provides a powerful system mid/high unit. The increased power in the bass range ensures a powerful sound in system and full-range applications.

Features

- Compact full-range mid/high unit with more power in the bass range
- 1200 W peak power bi-amped Class-D power amplifier
- Rotatable horn with 60° x 40° dispersion pattern
- Lockable, balanced XLR/TRS Combo input, balanced XLR output for analogue looping to an additional speaker
- Remote-controllable high-performance DSP with integrated directly selectable presets for the most common applications: Flat, Monitor, Low Cut, Remote
- Extensive DSP tools: fully parametric 10-band EQ with variable filter characteristics, High-Pass Filter, Low-Pass Filter, Polarity, Level, Delay, Limiter, Mute
- Professional, lockable EtherCon connector for connection to a Mac or PC to control the system
- DSP Out: balanced XLR output that transmits the processed signal from the speaker to a non-network-compatible speaker. The audio signal applied here can be extensively modified using the DSP CONTROL software
- HK AUDIO DuoTilt with 3° or 7° inclination
- Three reinforced M8 (AP-8) mounting points
- Lockable V-Lock mains cable
- Made in Germany



LINEAR 5 MK II 112 FA

Technical data

LINEAR 5 MK II 112 FA	
Max. SPL @ 10 % THD	128 dB half space (70 Hz - 12 kHz averaged)
Max. SPL Peak @ 10 % THD	135 dB half space
Frequency response +/-3 dB	70 Hz - 12 kHz
Frequency response -10 dB	55 Hz - 19 kHz
Power amp output (RMS/Peak)	600 / 1,200 W
Amplifier type	Class D - bi-amped
Woofers	-
Low/mid speaker	1 x 12", 2.5" voice coil
HF driver	1", 1.7" voice coil
Horn characteristics	60° x 40° CD horn, rotatable
Active x-over frequency	1.6 kHz FIR X-over with 72 dB/oct.
Maximum input level	20 dBu
Analogue inputs	1 x XLR combo balanced
Analogue Thru	1 x XLR balanced
DSP Out	1 x XLR balanced
Network port	EtherCON RJ45, 1 x In
Filter presets	Flat, Boost, Low Cut, Remote
Remote software	DSP CONTROL (Windows, Mac OS)
DSP functions	Fully parametric 10-band EQ with variable filter characteristics, High-Pass Filter, Low-Pass Filter, Polarity, Level, Delay, Limiter, Mute
Sample rate	48 kHz
System latency	Less than 2 ms
Mains connection	1x IEC connector with V-Lock securing system, 100-240 V
Power consumption	1 A / 100-240 V nominal according to EN 62368-1
Set-up angle (Monitor mode)	-
Pole mount	DuoTilt 3°/7°
Rigging points	3x M8 (AP-8)
Carrying handles	2 x MultiGrip
Housing	Hybrid (birch multiplex/MDF)
Surface	Black acrylic enamel
Front grille	2 mm metal grille backed with black acoustic foam
Dimensions (WxHxD)	37 x 67 x 36.5 cm 14-9/16 x 26-3/8 x 14-3/8"
Weight	21.9 kg / 48.28 lbs



Optional accessories



LINEAR 5 MK II Weather Protective Cover 112 FA

Part number: 1008046

Made to measure and equipped with many practical details, the Weather Protective Covers are the perfect protection against moisture and humidity, and at the same time a sturdy transport cover for all LINEAR 5 MK II mid/high units and subwoofers.

Behind the front flap, a waterproof acoustic gauze protects the front of the speakers and the drivers without affecting the systems' sound. The front flap can be simply and securely rolled up at the head end without interfering with stacking or clustering.

On the rear, sturdy, transparent viewing windows keep water away from the electronics, but ensure the settings can be read at all times and provide access to the controls as well as a cable entry.

The handles can still be used thanks to sealable recesses or notches. Sufficient ventilation of the electronics is ensured at all times.

- Tough rain and transport protection with easy handling
- Controls can be read and accessed at all times through transparent viewing windows
- Mounting poles can be used and installed with the protective cover in place
- Sturdy and discreet design
- Custom-fit covers are available for all LINEAR 5 MK II series units

Accessories for rigging and mounting



TB-45N

TB-45NQ

TB-45N / 45NQ

Part number: 1007972

The TB-45N and TB-45NQ are tilt brackets made of high-strength steel for mounting speaker cabinets on truss rods, ceilings, wall brackets, beams and tripods. The TB-45NQ is equipped with quick release pins for quick fitting. Both brackets have a WLL of 70 kg and a maximum load of 35 kg in accordance with DGUV-V 17 (German Social Accident Insurance Regulation 17). Flexible vertical and horizontal alignment is possible.



AP-8 attachment point

Part number: 1007538

With a high load capacity of up to 360 kg (WLL), or 180 kg within the scope of BGV-C1, the AP-8 Attachment Point allows for the safe installation of speaker cabinets with M8 rigging points on steel cables or chains.

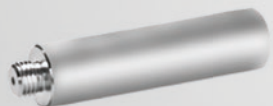

Tilt-Unit

Part number: 1007972

The Tilt Unit allows the mid/high units to be tilted directly on the subwoofer without a mounting pole. Like a mounting pole, the Tilt Unit is screwed directly into the M20 mount of the LINEAR 5 MK II SUB. This means that the DuoTilt can also be used at tilt angles of both -3° and -7° in a stack setup, and the Tilt-Unit prevents the mid/high units from slipping.

LINEAR 5 MK II 112 FA

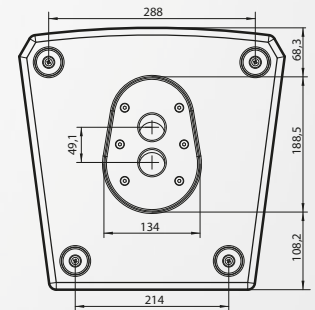
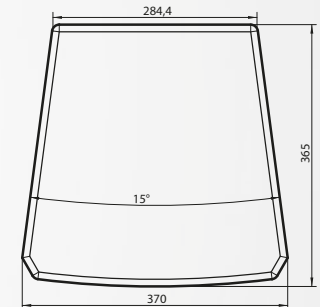
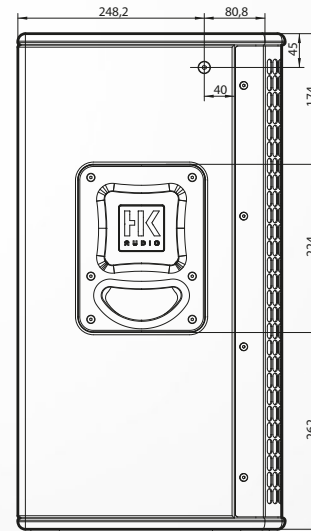
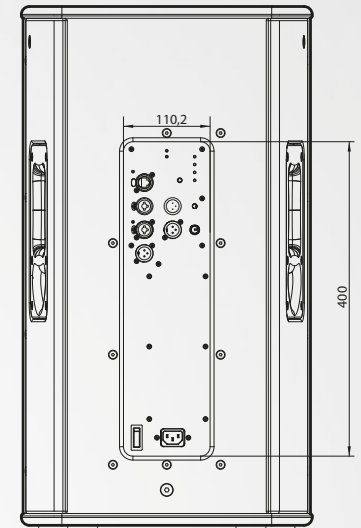
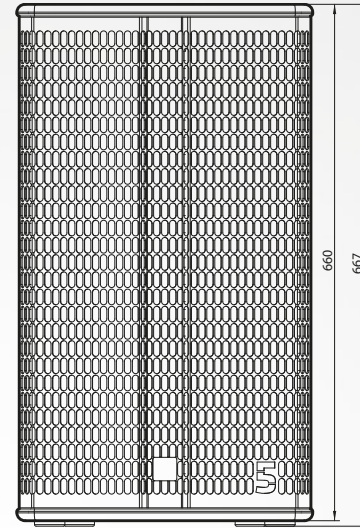
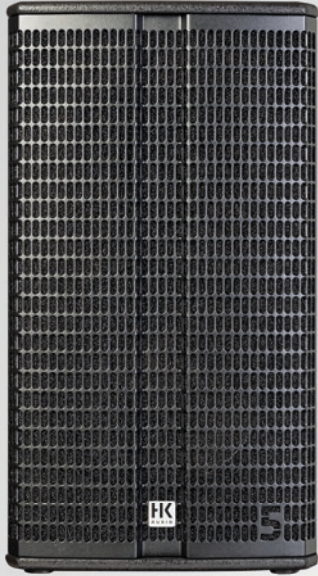

Simulation and CAD files, certificates
and much more can be found at www.hkaudio.com

HK Audio
Postfach 1509 • 66595 St. Wendel, Germany
info@hkaudio.com • www.hkaudio.com • fax +49-68 51-905 215

Subject to change without notice
Copyrights 2023 Music & Sales GmbH 01/2023

D-3246